

Friction type torque limiter

(Safety coupling)

Torque up to 23000 Nm, 140 mm opening

BF



BMOOM
Torque Limiter

Shanghai Bmoom Electromechanical Co.,Ltd
上海宝牧机电设备有限公司

BF - Friction Torque Limiter: Description



- Simple and economical friction type torque limiter.
- It is suitable for working in dusty conditions, and there is no need to adjust the speed between the gear box and the output device.
- No noise or vibration when overloaded.
- Rotation two-way protection.
- Non-asbestos friction disc.
- Through the adjustment of the locking ring, the torque setting is simple and precise.
- According to the size and innovative calibration system, the equipment can be calibrated instantaneously.
- ▲ On demand
- Complete transmission gears, all turned and assembled (sprockets, pulleys, gear pairs).
- All kinds of friction plates suitable for specific purposes.
- Multiple connection methods such as keyway, spline, expansion sleeve, etc. can be provided.
- The surface layer is treated with anti-corrosion to meet special requirements.

The sprocket, pulley or other transmission components in the friction torque limiter are installed between the two sliding plates. When the torque is reached, it can ensure continuous transmission without damaging the components. The characteristics of the device are: simple structure, low price, suitable for use in environments where torque accuracy is not very high.



■ main application

- Forming machinery.
- Conveying machinery.
- Fan.
- Agricultural machinery,
- woodworking machinery.

■ Advantages and features

- Protect the motor gearbox in an accidental collision.
- In the case of overload, the conveyor line can be stopped in time.
- Protect the motor and blade when the blade is stuck.
- In the case of short-term blockage of the product, the gear is protected.

▲ On-demand

	BF : The basic model of parallel shaft transmission, with sprocket, gear pair or pulley.	1-23000 Nm Maximum opening 140 mm	33 pages
	BF-T : Coaxial connection, simple and economical structure.	1- 23000 Nm Maximum opening 160 mm	43 pages
	BF-G : Coaxial connection, with elastic coupling, large compensation range.	1- 23000 Nm Maximum opening 160 mm	53 pages

■ Application example

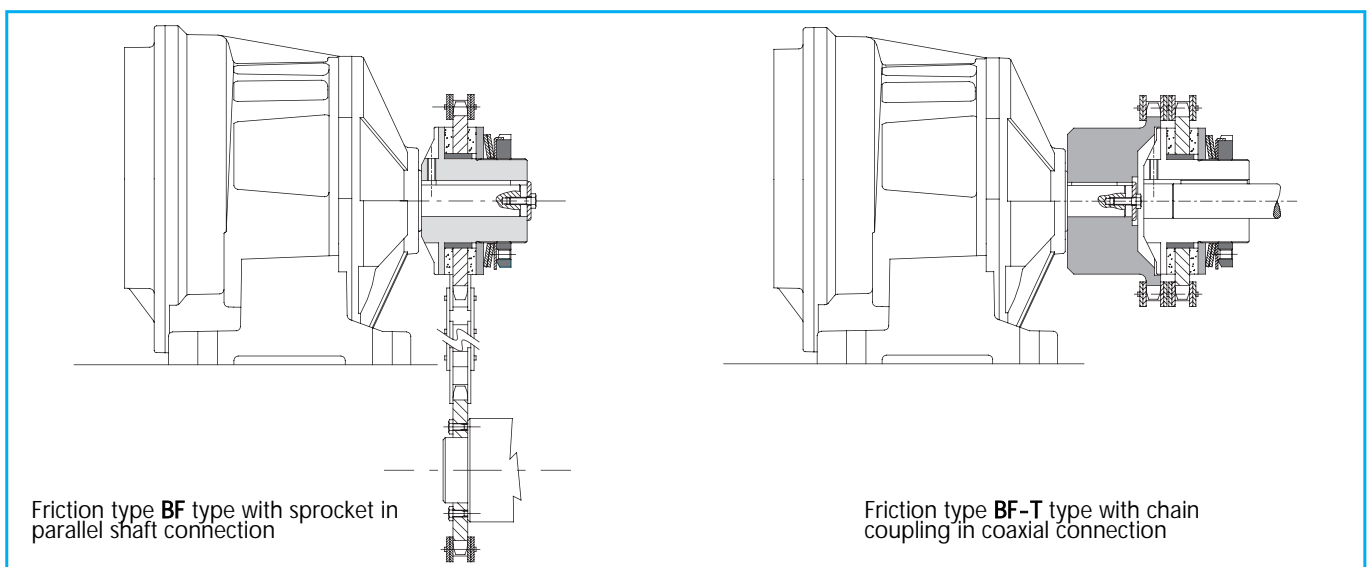

BF-Friction torque limiter: technical data

- ⊙ Simple, compact solution.
- ⊙ This version can be equipped with a coil spring for precise adjustment: .../CM. It can work under anti-corrosion conditions: BF/EA.
- ⊙ Can be customized configuration (摺).
- ⊙ Radial locking can be achieved by the radial ring: .../GR.
- ⊙ The torque range is: 1-23000 Nm; the maximum opening is 140 mm.

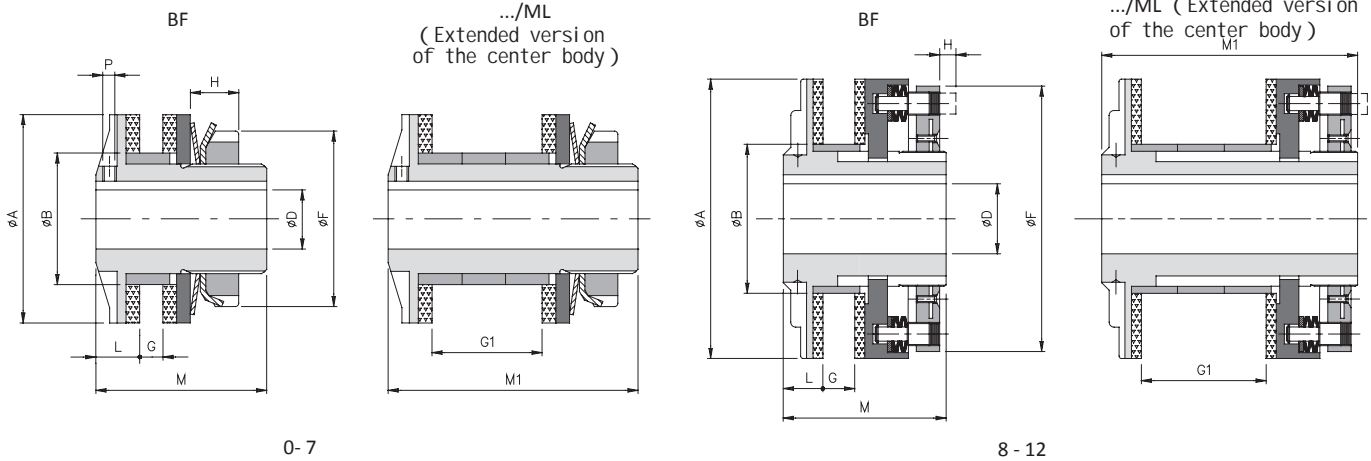

Di mensions ■

size	A	B h7	DH7		F	G		G1 maximum	L	M	M1	P *
			Prefabri cated hole	maxi mum		The smal lest	maxi mum					
0	25	14	-	8	22	1	3	-	5	26	-	M3*
1	38	24	-	12	32	1	5	21	8	33	46	M3
2	50	36	-	20	44	1	6	26	10	35	57,5	M4
3	70	45	-	25	63	1	10	40	15	55	85	M6
4	90	60	-	38	82	3	12	46	16	60	95	M6
5	115	72	18	45	104	5	16	58	18	70	113	M6
6	140	85	24	55	130	8	19	69	20	80	136	M8
7	170	98	28	65	158	10	22	78	22,5	95	153,5	M8
8	205	120	38	80	193	18	26	90	27	110	174	-
9	240	145	50	100	230	18	29	99	27	116	186	-
▲ 10	300	175	60	120	287	21	33	113	29	123	203	-
▲ 11	340	205	60	130	325	23	33	113	41	158	238	-
▲ 12	400	230	60	140	388	23	35	119	46	167	251	-

Technical details ■

si ze	Torque[Nm]				inertia [10 ⁻³ kgm ²]	Maximum speed [Rpm]	weight[kg]	
	T0	T1	T2	T3			BF	.../ML
0	-	1 - 8	2 - 12	2 - 20	0,003	10000	0,1	-
1	-	1 - 14	8 - 22	15 - 34	0,022	10000	0,2	0,3
2	2 - 12	4 - 40	17 - 70	23 - 100	0,075	7600	0,4	0,5
3	6 - 18	17 - 60	34 - 120	60 - 210	0,390	5450	1,1	1,4
4	13 - 105	74 - 140	90 - 280	185 - 450	1,167	4250	2,2	2,8
5	65 - 280	120 - 360	207 - 700	210 - 950	3,809	3350	3,7	4,8
6	-	180 - 550	260 - 950	390 - 1200	9,982	2750	6,6	8,5
7	-	160 - 700	300 - 1450	1000 - 2600	23,943	2250	10,9	13,5
8	300 - 1200	500 - 2400	1000 - 4800	-	75,088	1900	20,1	24,5
9	500 - 2000	1000 - 4000	2000 - 8000	-	152,946	1600	30,9	37,8
▲ 10	800 - 3500	1500 - 7000	3000 - 14000	-	380,357	1300	49,1	60,8
▲ 11	1000 - 4500	2000 - 9000	4000 - 18000	-	869,290	1200	85,5	102,5
▲ 12	1500 - 5000	3000 - 11000	5000 - 23000	-	1830,092	1000	124,5	147,7

Description

- P * : The size is 00.25, and the flat head screw is located on the nut side instead of on the flange side.
- The weight is related to the torque limiter (BF) with pre-made holes, and the inertia refers to the maximum diameter of the hole.

BF-T Version with chain coupling: technical data



- A simple, compact solution for coaxial drives.
- Two-way rotation protection.
- Different types of friction discs can be equipped to meet specific applications.
- This version is equipped with a pair of coil springs, which can accurately adjust the combination: .../CM/T can achieve radial locking adjustment: .../GR.
- Torque range: 1-23.000 Nm; maximum opening: $\varnothing 160$ mm.

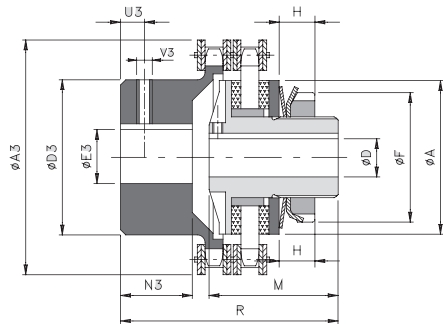

0-7

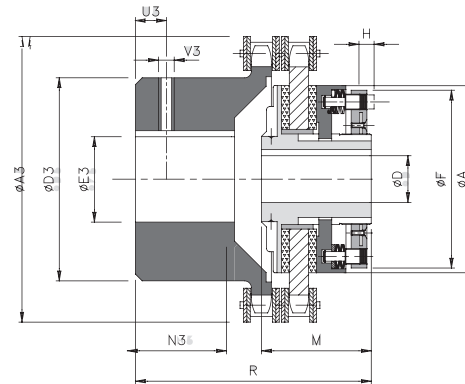

8-12

Dimensions

size	A	D H7		F	M	R	A3	D3	E3 H7		N3	U3	V3
		Prefabricated hole	maximum						Prefabricated hole	maximum			
0	25	-	8	22	26	39	45	23	8	12	9	4	M3
1	38	-	12	32	33	58	57	37	10	20	20	5	M3
2	50	-	20	44	35	58	75	50	12	28	19	8	M4
3	70	-	25	63	55	87	101	70	16	38	29	12	M6
4	90	-	38	82	60	102	126	89	20	55	38	12	M6
5	115	18	45	104	70	131	159	112	20	70	56,5	15	M8
6	140	24	55	130	80	145	184	130	28	80	59,5	15	M8
7	170	28	65	158	95	189	215	130	30	80	88	15	M8
8	205	38	80	193	110	218	291	150	38	90	103	25	M10
9	240	50	100	230	116	245	310	170	50	110	124	25	M10
10	300	60	120	287	123	284	374	200	50	140	147	30	M12
11	340	60	130	325	158	329	423	210	60	150	165	30	M12
12	400	60	140	388	167	364	471	240	60	160	191	30	M16

Technical details

size	Torque [Nm]				compensation			Maximum speed [Rpm]	weight [Kg]
	T0	T1	T2	T3	angl ea [°]	Axi al X [mm]	Radi al K [mm]		
0	-	1 - 8	2 - 12	2 - 20	2°	1,50	0,20	5000	0,2
1	-	1 - 14	8 - 22	15 - 34		1,50	0,20	5000	0,6
2	2 - 12	4 - 40	17 - 70	23 - 100		1,50	0,20	3800	1,1
3	6 - 18	17 - 60	34 - 120	60 - 210		2,40	0,25	2800	2,8
4	13 - 105	74 - 140	90 - 280	185 - 450		3,20	0,30	2200	5,9
5	65 - 280	120 - 360	207 - 700	210 - 950		4,50	0,35	1800	11,1
6	-	180 - 550	260 - 950	390 - 1200		4,80	0,40	1500	20,3
7	-	160 - 700	300 - 1450	1000 - 2600		4,80	0,40	1300	31
8	300 - 1200	500 - 2400	1000 - 4800	-		6,30	0,50	1000	54,6
9	500 - 2000	1000 - 4000	2000 - 8000	-		6,30	0,50	900	76,7
10	800 - 3500	1500 - 7000	3000 - 14000	-		6,80	0,55	700	125,5
11	1000 - 4500	2000 - 9000	4000 - 18000	-		6,80	0,55	600	180
12	1500 - 5000	3000 - 11000	5000 - 23000	-	6,80	0,55	550	260	

Description

" This data is related to the entire combination (BF-T).
 "The weight is related to how big the inner hole is (BF-T).

BF-G Models with claw coupling: technical data

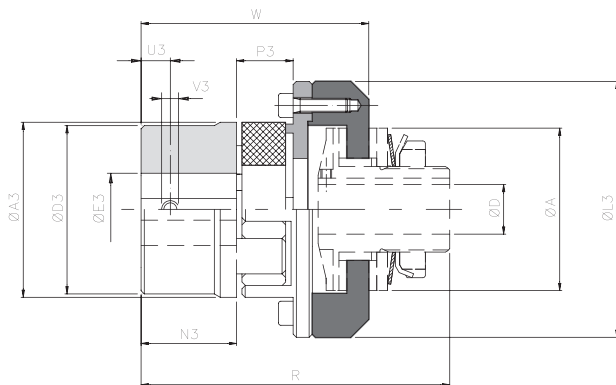

Dimensi ons

Size	A	D H7		F	M	R	A3	L3	E3 H7		N3	U3	V3
		Prefabricated hole	maximum						Prefabricated hole	maximum			
0	25	-	8	22	26	56	30	43	-	16	11	5	M4
1	38	-	12	32	33	84.5	40	58	-	25	25	10	M4
2	50	-	20	44	35	58	55	74	-	35	30	10	M5
3	70	-	25	63	55	87	80	107	-	48	45	15	M8
4	90	-	38	82	60	102	95	132	-	55	50	20	M8
5	115	18	45	104	70	131	120	164	-	74	65	20	M10
6	140	24	55	130	80	145	160	208	28	95	85	25	M10
7	170	28	65	158	95	189	200	246	30	110	100	30	M12
8	205	38	80	193	110	218	225	285	38	115	110	30	M12
9	240	50	100	230	116	245	255	330	50	125	120	33	M16

5

Technical details

Size	Torque[Nm]				compensation			Maximum speed [Rpm]	weight [Kg]
	T0	T1	T2	T3	angle α [°]	Axial X [mm]	Radial K [mm]		
0	-	1 - 8	2 - 12	2 - 20	0.54°	1	0.09	10000	0,2
1	-	1 - 14	8 - 22	15 - 34	2°	1	0.20	10000	0,4
2	2 - 12	4 - 40	17 - 70	23 - 100		1	0.22	7600	0.8
3	6 - 18	17 - 60	34 - 120	60 - 210		1.4	0.28	5450	3.3
4	13 - 105	74 - 140	90 - 280	185 - 450		1.6	0.32	4250	5.4
5	65 - 280	120 - 360	207 - 700	210 - 950		1.8	0.38	3350	10.3
6	-	180 - 550	260 - 950	390 - 1200		2.5	0,48	2750	21.1
7	-	160 - 700	300 - 1450	1000 - 2600		2.8	0,50	2250	36.3
8	300 - 1200	500 - 2400	1000 - 4800	-		3.0	0.52	1900	59.9
9	500 - 2000	1000 - 4000	2000 - 8000	-		3.2	0.55	1600	87.7

BF - Friction torque limiter: additional information

Order example

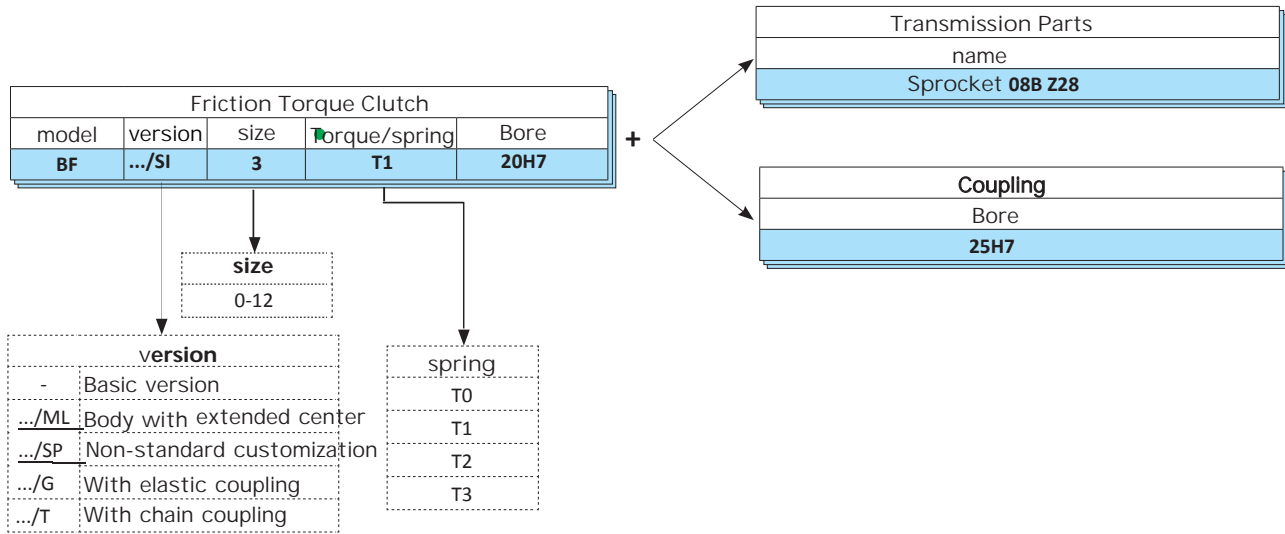

6

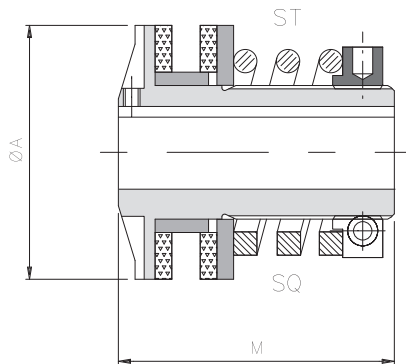

On-demand version

.../CM: minimum torque version

Equipped with spiral spring, it is suitable for a relatively wide torque range and can be accurately calibrated.

size	Torque[Nm]		A	M1
	spring ST	springsQ		
2	1,5 - 9	-	50	57,5
3	2 - 34	2 - 60	70	85
4	5 - 56	3 - 70	90	95
5	10 - 130	25 - 160	115	113

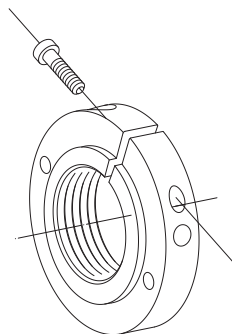

.../GR: Model with radial adjusting nut

The adjusting nut has a radial locking static balance function, which is an alternative to the GT standard groove top nut. Applicable size range: 1-7

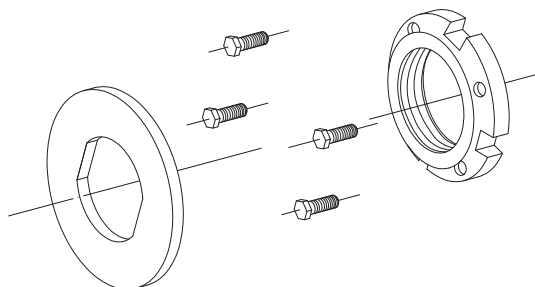

GT/DR tool: Two-way matching tool, matching with the nut through the slot GT.

The torque adjustment system is equipped with two-way matching (flange and hexagonal screws) tools to ensure the sensitivity and accuracy of calibration, and is equipped with disc gaskets.